

INSTALLATION, OPERATION AND MAINTENANCE

Series 7000, 8000 and 9000 Flo-Gage™

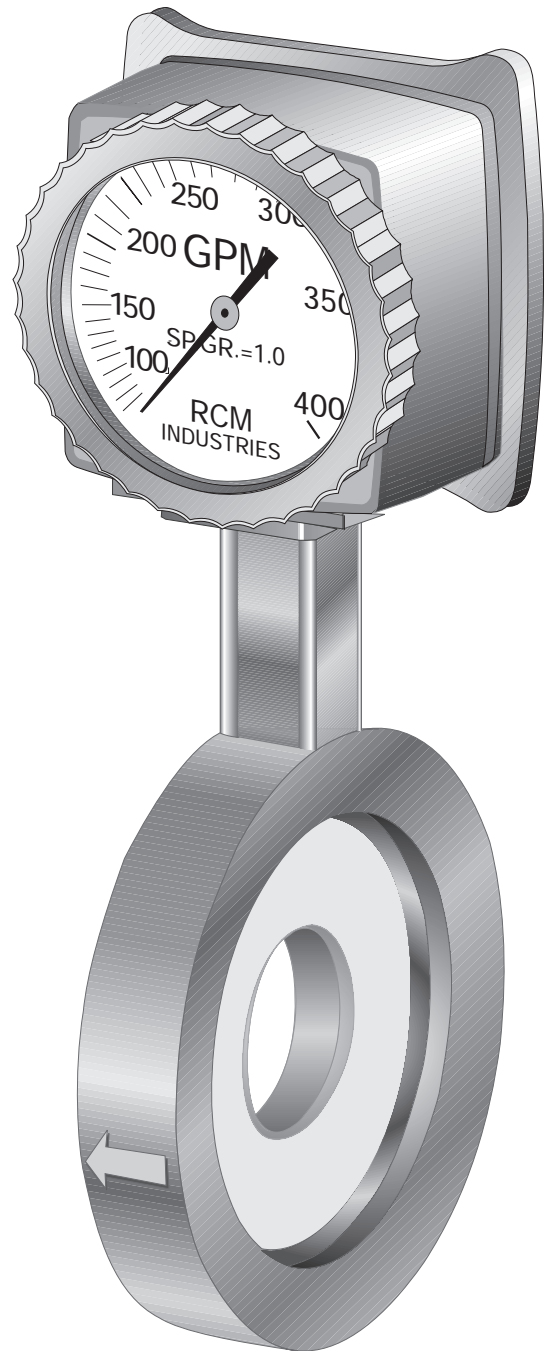

Table of Contents

	Page
1. Principle of Operation	2
2. Installation Planning	2
3. Installation	3
3.1 Safety Considerations	3
3.2 Changing the Dial Orientation	3
3.3 Changing from Horizontal to Vertical	3
3.4 Series 7000	3
3.5 Series 8000	3
4. Operation and Maintenance	4
4.1 Preventive Maintenance	4
4.2 Checking Zero	4
4.3 Checking the Pointer Preload	4
4.4 Coarse Zero Adjustment	4
4.5 Fine Zero Adjustment	5
4.6 Flow Calibration	5
4.7 Cleaning of Pressure Ports	6
4.8 Adjustment of Reed Switches	6
5. Troubleshooting	6
5.1 Pointer Fluctuations	6
5.2 Zero Shift	7
5.3 Sluggish Meter Response	7
6. Correction Factors	7
6.1 Liquid Service	7
6.2 Compressed Gas Service	7
7. Parts List	8

Figures

Figure 1	Series 8000 Flo-Gage	1
Figure 2	Installation conditions	2
Figure 3	O-ring installation	3
Figure 4	Zero reference point.....	4
Figure 5	Pointer preload	4
Figure 6	Cam nut and stop nut	5
Figure 7	Cam follower adjustment.....	6



Series 8000 Flo-Gage
Figure 1



1.

Principle of Operation

RCM Series 7000 and Series 8000 Flo-Gages measure flow rate by sensing the pressure differential created across the flow nozzle which is machined into the body of the flowmeter. A pair of matched, opposed bellows sense the differential pressure and drive a mechanical linkage to indicate flow rate directly on the dial. (When fitted with options RW2, the bellows and mechanical linkage are replaced with a solid state differential pressure sensor and digital readout.)

2.

Installation Planning and Site Selection

Select a site which is convenient for viewing and which provides service access to the front and rear of the flowmeter. Note that the dial can be ordered in any orientation at 90 degree increments and can be easily reoriented in the field. See "Changing the Dial Orientation" in the installation section. The site selected should provide at least 10 pipe diameters of straight meter size pipe between the meter inlet and any upstream fitting such as elbow, tee or valve. There are no special piping requirements for downstream connections to the meter.

Note that the meters (except those with sanitary connections, which are calibrated for tubing) are calibrated based on schedule 40 pipe connections. Tubing or hoses do not have the same ID as pipe and should be transitioned to pipe at least 10 diameters upstream of the meter to achieve rated accuracy.

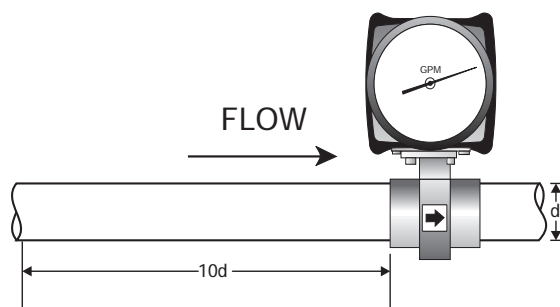

Installation Conditions
Figure 2

Avoid placing the meter where it will be subjected to water hammer and mount the meter rigidly to minimize shock or vibration.

Meters installed outdoors or exposed to splashing liquids should be ordered with a gasketed case.



3.

Installation

3.1 Safety Considerations

Do not exceed the pressure and temperature limits marked on the nameplate of the meter. Although each meter is pressure tested to 150% of nameplate rating, overpressure may cause injury, leaking or meter damage.

Temperature ratings are determined by the effects on the mechanical linkage, elastomer seals and electronics (if electronics are fitted). If temperature ratings are exceeded, the meter may be damaged or fail. Contact the factory for application assistance for expanded temperature operation.

3.2 Changing the Dial Orientation

Note the flow direction arrow on the body. If necessary, change the dial facing direction by removing the four screws holding the body to the housing. **Do not remove the two screws holding the housing to the cell block assembly.**

Position the housing at any 90 degree position. Replace the four screws taking care not to pinch the o-ring seals.

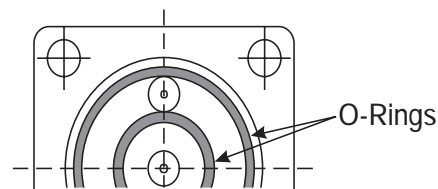

O-Ring Installation
Figure 3

3.3 Changing from Horizontal to Vertical or Vertical to Horizontal

Remove the lens by rotating counter-clock wise by hand. **Do not remove the pointer.** Move the dial forward by tapping the gage lightly or by using a small piece of masking tape. Rotate the dial to the desired viewing position and push the dial back into position. There are 4 locating indents on the dial edge to position the dial at 90 degree increments.

Rezero the meter using the FINE ADJUSTMENT procedure.

3.4 Series 7000 (threaded)

Make up thread joints using a suitable thread sealant. Be sure threads are clean and free of burrs before making up joints. Apply wrench torque only to the meter body. **DO NOT** exert any wrenching force to the meter housing.

3.5 Series 8000 (flanged)

Install the meter between mating flanges. Take care to center the gaskets so that they do not protrude at all into the pipeline. Gasket protrusion will cause significant calibration errors.



4.

Operation and Maintenance

4.1 Preventative Maintenance

The meter does not require routine lubrication or service of any kind. Keep the interior of meter housing clean and free of dust, moisture, oils or corrosive materials. Protect the meter from dripping or splashing corrosives or solvents which may attack meter exterior and eventually damage the internal mechanism.

4.2 Checking Zero

Water hammer or pressure surges can displace the bellows and cause the zero to shift. If the pointer does not return to the stop pin when flow through the meter is zero, or if the pointer does not move away from the stop pin at 12-15% of full scale flow, then check the zero adjustment as follows:

- Stop flow.
- Remove the lens.
- Observe the position taken by the pointer. When properly adjusted, the pointer should point to the zero reference point as shown in Figure 4.
- If the pointer is positioned within 1/2" (12 mm) of stop pin, then follow FINE ADJUSTMENT procedure to rezero pointer.
- If the pointer is positioned more than 1/2" (12 mm) from the stop pin, then follow the COARSE ADJUSTMENT procedure.

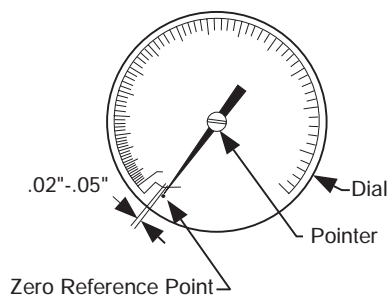

Zero Reference Point
Figure 4



Pointer preload
Figure 5

4.3 Checking the Pointer Preload

If the fine adjustment has been performed repeatedly, the pointer return spring preload should be checked. Manually rotate the pointer CCW toward full scale. The pointer should stop at full scale. If the pointer goes beyond full scale, adjust with the cam nut following the COARSE ADJUSTMENT procedure. Otherwise, go to the FINE ADJUSTMENT procedure.

4.4 Coarse Zero Adjustment

If necessary to restore spring preload, place a small screwdriver in the slotted pointer hub. Grip the pointer close to the hub on both sides of the hub and rotate the hub approximately one-quarter turn clockwise with respect to the pointer. Check preload by rotating the pointer CCW toward full scale. When properly adjusted, the pointer should stop at full scale.



4.

Operation and Maintenance (Continued)

Release the pointer. Using the cam nut, adjust the lever so that the pointer points to the zero reference point.

Check the position of the stop nut. Applying force to the stop nut, manually move the center shaft to the right (as seen from the rear) and make certain that the stop nut contacts the cell block when the pointer stops. If necessary, adjust the stop nut to stop the pointer near the 6 o'clock position. The factory set point is the "U" in "USA".

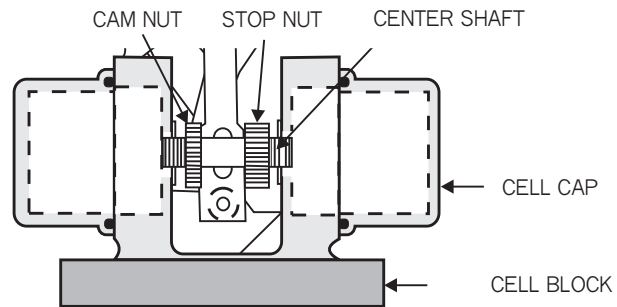

Cam nut and stop nut
Figure 6

IMPORTANT. The stop nut must stop the center shaft movement before the bellows hit the cell cap. If the bellows hit the cell cap, the bellows or the cap can be damaged causing leaking or meter errors.

Adjust the cam nut until the pointer points at the zero reference point. Gently tap the meter to overcome residual friction while making the adjustment.

Test for freedom of pointer movement by rotating the pointer approximately 30 degrees and releasing. Pointer should return quickly to the zero reference. Clean and reinstall the lens.

4.5 Fine Zero Adjustment

Note: If fitted with transmitter model W, X, Y or Z or with reed switches, do not use this procedure. Do all adjustments with the coarse zero adjustment. Adjustment of the fine zero using this method will require recalibration of reed switches or transmitter.

Grip the pointer close to the hub on both sides of the hub and rotate the hub with respect to the pointer. The pointer should aim directly at the "zero reference point" printed on the dial as shown in figure 4.

Gently tap the meter to overcome residual friction while making the adjustment. Test for freedom of pointer movement by rotating the pointer approximately 30 degrees and releasing. Pointer should return quickly to zero reference. Clean and reinstall lens.

4.6 Flow Calibration

The orifice has been factory adjusted to provide the proper differential pressure for accurate meter operation. Meters are factory calibrated with water prior to shipment. NIST traceable certifications are available when ordered prior to shipment or may be obtained by returning the meter for recalibration. Field calibration may be verified using the following procedure:

Check the zero adjustment of the pointer. Cycle the flow rate from zero to full scale three or four times and observe the pointer motion. Pointer should return to zero smoothly.



4.

Operation and Maintenance (Continued)

Establish a known flow rate through the meter corresponding to approximately 90% of full scale and observe the meter indication. Move the cam follower up to decrease the pointer indication or down to increase the pointer indication.

To move the cam follower up, rest a screwdriver on the cell block with the blade between the cell block and the center shaft. Pry gently up on the cam follower. To move the cam follower down, place a screwdriver on the top of the cam follower. With the blade resting against the case press gently down. Take care not to put excessive forward pressure on the cam follower to prevent the "C" clip on the pivot shaft from coming off. Rezero the meter using the cam nut.



Cam Follower Adjustment
Figure 7

Check meter indication at 50% of full scale. Meter should indicate actual flow rate within 3% of full scale. If meter does not indicate actual flow, consult factory.

4.7 Cleaning of Pressure Ports

Remove the meter housing from the body by removing 4 screws. Remove the pulsation snubbers from the body by inserting a small wood screw into the hole in the pulsation snubbers and gently pull them out. Clean passages in body and snubbers and reassemble. If you are unable to clean without further disassembly, the meter should be returned to the factory for service.

Reassemble the meter housing to the body in the desired viewing position. Take care to properly seat the inner and outer o-rings before tightening screws.

4.8 Adjustment of Reed Switches

Check the meter zero and correct if necessary using the coarse or fine zero procedure before proceeding. Connect continuity tester to N.O. contact. Loosen the switch clamp. Establish the desired flow rate for switch tripping. Slide switch to left most position. Slowly slide to right while monitoring N.O. contact. Switch will close. Continue to slide to right. Switch will open (false trigger). Continue to slide to right until switch closes again. Adjust by sliding to right to raise setpoint, left to lower. Tighten clamp. Note: Tiny adjustments may be required to reach the desired set point.

5.

Troubleshooting

5.1 Pointer Fluctuation

Mechanical fluctuation of the pointer is usually a symptom of excessive turbulence in the pipeline. This is frequently caused by valves or fittings installed too close to the meter inlet. If moving the meter is not practical, snubbers with smaller holes can be installed to increase the mechanical damping of the meter. (Pulsation snubbers are installed standard on all gas meters and on liquid meters unless ordered with viscosity correction.)



5.

Trouble-shooting (Continued)

5.2 Zero Shift

The need to frequently rezero the meter is an indication of excessive water hammer. Piping or operating procedures should be changed to reduce water hammer in order to prolong the life of the meter.

5.3 Sluggish Meter Response

Sluggish meter response can be caused by inadequate pointer return spring preload or by clogging of the pressure passages with debris. To check spring preload, see CHECKING THE POINTER PRELOAD. To clean the pressure passages, see CLEANING OF PRESSURE PORTS.

6.

Correction Factors

6.1 Liquid Service

If the specific gravity of the fluid being metered differs from the value marked on the meter dial, a correction factor, J, must be applied to the meter reading to obtain the actual flow rate.

Actual flow rate = J x meter reading

where $J = \sqrt{\frac{Sc}{Sa}}$

Sc = Specific gravity for which meter is calibrated

Sa = Actual specific gravity of fluid being metered

Example:

Meter, calibrated for water (specific gravity = 1.0) reads 12.5 GPM for a lubricating oil with specific gravity of 0.85. What is the actual flow rate?

$$J = \sqrt{\frac{1.0}{0.85}} = \sqrt{1.1765} = 1.085$$

Therefore, actual flow = 1.185 x 12.5 = 13.56 GPM

6.2 Compressed Gas Service

If the gas pressure or temperature varies from the values marked on the meter dial, then a correction factor, K, must be applied to the meter reading to obtain the actual flow rate.

Actual flow rate = K x meter reading

where $K = \sqrt{\left(\frac{(Pa + 14.7)}{(Pc + 14.7)}\right)\left(\frac{(Tc + 460)}{(Ta + 460)}\right)}$

Pa = Actual gas pressure at entrance to meter, psig.

Pc = Calibrated gas pressure marked on the meter dial, psig.

Ta = Actual gas temperature at meter, °F

Tc = Calibrated gas temperature marked on meter dial, °F



6.

Correction Factors

(Continued)

Example:

Meter calibrated for compressed air at 100 °F and 80 psig. reads 100 SCFM at an actual temperature of 70 °F and pressure of 85 psig. What is the actual flow rate?

$$K = \sqrt{\left(\frac{85 + 14.7}{80 + 14.7}\right) \left(\frac{100 + 460}{70 + 460}\right)}$$

$$K = \sqrt{(1.04)(1.06)} = 1.05$$

Therefore, actual flow rate = 1.05 x 100 = 105 SCFM

7.

Parts List

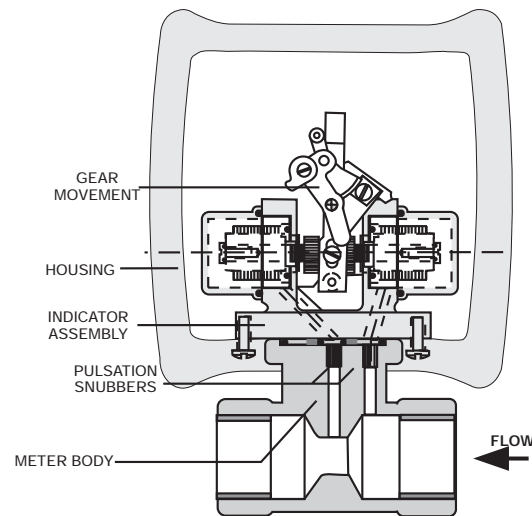

Cutaway View From Front Dial & Dial Bracket Removed
Figure 8

Back cover plate, standard	6133	Gear movement, brass	1361
Back cover plate, w/conduit entrance (switch options)	6299	Gear movement, 316 SS	6167
Back cover plate, w/term.	6298	*O-ring seals	
cutout and conduit and gaskets		O-ring seals, set of 8, buna-n	6103
Crystal, polycarbonate	6131	O-ring seals, set of 8, viton	6104
Dial, specify scale and range	6264	O-ring seals, set of 8, EPR	6105
Gasket, back cover plate	6138	O-ring seals, set of 8, teflon	6106
Gasket, crystal	6137	*Pointer	1481
Gasket, body flange	3651	Pulsation snubbers (2 required)	
Gaskets (for housing),	6300	light duty	6309
set of 9		standard	6307
		heavy duty	6308

* Recommended spare parts

