



RCM

FLO-GARD™ INLINE FLOW SWITCHES

RCM's broad range of flow switches provide economical solutions for equipment protection and automation.

- **All FLO-GARD™ flow switches provide high reliability design with no paddles, or small flow paths to plug or stick.**

Switches are suitable for measuring dirty water containing particulates and debris. Switches may also be selected for gases and steam.

- **Wide range of sizes and materials for optimal selection.**

Choose one or two field adjustable switch set points from 0.5 gallons per hour (1/2") to 3000 GPM (8"). All switches are independently adjustable from 15% to 100% of range.

- **Maintenance-free Design**

FLO-GARD™ flow switches operate on the differential pressure principle and have no bearing or sliding surfaces to corrode and stick. Normal maintenance is NOT required.

- **Low Installation Cost**

FLO-GARD™ flow switches include a terminal strip and splash-proof junction box for making field connections, eliminating the cost of providing a field junction box.



ISO-9001



DNV

CERTIFICATED FIRM

RCM Industries, Inc.



STANDARD FLOW RANGES & SIZES

Size in mm						Maximum Flow Range				
1/4	1/2	3/4	1	1 1/2	2	liquid		gas		steam
						GPM	l/m	SCFM	Nm ³ /h	#/h
■	■					2	8	10	15	40
■	■					3	10	20	30	60
■	■					4	15	30	50	80
■	■	■				6	25	40	80	120
■	■	■				10	40	60	100	200
■	■	■	■			15	60	100	250	300
■	■	■	■			20	80	200	400	400
■	■	■	■	■		30	120	300	500	600
■	■	■	■	■		40	150	400	600	800
■	■	■	■	■	■	60	240	600	1000	1000
■	■	■	■	■	■	100	400	800	1200	2000
■	■	■	■	■	■	150	600	1000	1500	3000
■	■	■	■	■	■	200	800	1200	2000	4000
2 1/2	3	4	5	6	8	GPM	l/m	SCFM	Nm ³ /h	#/h
65	80	100	125	150	200	60	240	600	1000	1000
■						100	400	800	1200	2000
■						150	600	1000	1500	3000
■	■					200	800	1200	2000	4000
						GPM	l/m	SCFM	Nm ³ /m	#/h
■	■	■				300	1000	1500	50	6000
■	■	■				400	1500	3000	100	8000
■						500	2000	4000	100	10000
■	■	■	■			600	2400	5000	150	15000
■	■	■	■	■		800	3000	6000	200	20000
■	■	■	■	■	■	1000	4000	8000	250	40000
■	■	■	■	■	■	2000	8000	15000	400	40000
■	■	■	■	■	■	3000	12000	20000	600	60000

Example: A meter with a max flow range of 100 has a useful range from 15 to 100.

Useful Range (All Units of Measurement)	
Min.	Max.
0.2	1
0.3	2
0.4	3
0.5	4
0.5	6
1.0	8
1.5	10
2	15
3	20
3	25
4	30
6	50
5	60
10	80
15	100
15	120
20	150
30	200
30	240
30	250
40	300
50	400
50	600
100	800
150	1000
200	1500
300	2000
400	3000

Female threaded connections available 1/4" - 2" and 3" (08 mm - 50 mm & 80 mm)
 Flanged (wafer) connections available 1/2" - 8" (15 mm - 200 mm)
 Metric threads not available in stainless steel.

OPTIONAL LOW FLOW RATES (OPTION ES)

Size		Maximum Flow Range				
in	mm	liquid			gas	
		GPH	l/h	cc/m	SCFH	Nm ³ /h
1/2	15	4	15	200	40	1
1/2	15	6	20	300	60	2
1/2	15	10	40	400	100	3
1/2	15	15	60	600	150	4
1/2	15	20	80	1000	200	6
1/2	15	30	120	2000	300	8
1/2	15	40	150	3000	400	10
1/2	15	60	240	4000		
1/2	15	100	400	6000		

OPTIONS

- A Viton™ seals
- B EPR seals
- B2 TFE seals
- ES Low flow rate (below 2 GPM)
- I Compressed gas service
(specify gas name, temperature and pressure)
- K Steam service (max 120 psig.)
- T Expanded temperature range (-80° F to 350 °F).
Consult factory for higher temperatures.



SELECTION

Select a switch with a maximum flow range greater than the required switch point. Best performance at minimum pressure drop occurs at approximately 50% of maximum flow range.

Select a) body size, b) end connections, c) material, d) maximum flow rate, e) options (if required) and f) number of switches.

A) BODY SIZE - pipe size at the meter inlet. Select from Standard Flow Ranges and Sizes, page 2.

B) SERIES (end connections)

1 - threaded units provided with FNPT connections standard. FBSP parallel threads available on request for bronze meters.

2 - wafer units mount between any standard 150 or 300 class flanges (or international equivalent).

C) MATERIAL -

1 = Bronze **3** = Stainless steel (316)

D) FLOW RATE (maximum) - Select from Standard Flow Ranges and Sizes, page 2. Prefix full scale with "M" for metric units.

E) OPTIONS - Select from table of Options. Note: For gas service, select option I and specify gas being measured, inlet temperature and pressure.

F) NUMBER OF SWITCHES

1S2 - One single pole double throw switch

2S2 - Two single pole double throw switches

EXAMPLE: 3/4-1-20-A-1S2

is the catalog number for a 3/4" NPT Series 1000 Flo-Gage of bronze construction, flow range of 20 GPM maximum scale, equipped with optional seals of Viton, and one single-pole double throw reed switch.

SPECIFICATIONS

FLO-GARD™

	Standard	Optional
Pressure, max.	400 psig, (28.1 kg/cm ²)	
Temperature, max.	212°F (100°C)	350°F (177°C)
Temperature, min.	-30°F (-34°C)	-80°F (-62°C)
	<i>Protect from freezing liquids</i>	
Pressure drop	5 psig at max flow 1.2 psig at 50% of max flow	

REED SWITCHES

Setability	±5% F.S.
Repeatability	±1% F.S.
Hysteresis	7 to 13% F.S.
Contact Rating	3 watts
Voltage	100 vdc - max.
Current	250mA max. switching 1.0 Amp max. carry

CONSTRUCTION SPECIFICATIONS

Housing	Aluminum Polyester coated
Pressure Cell Body	Aluminum, hard anodized Bronze 316 SS
Bellows	Bronze 316 SS Inconel (high pressure)

DIMENSIONS

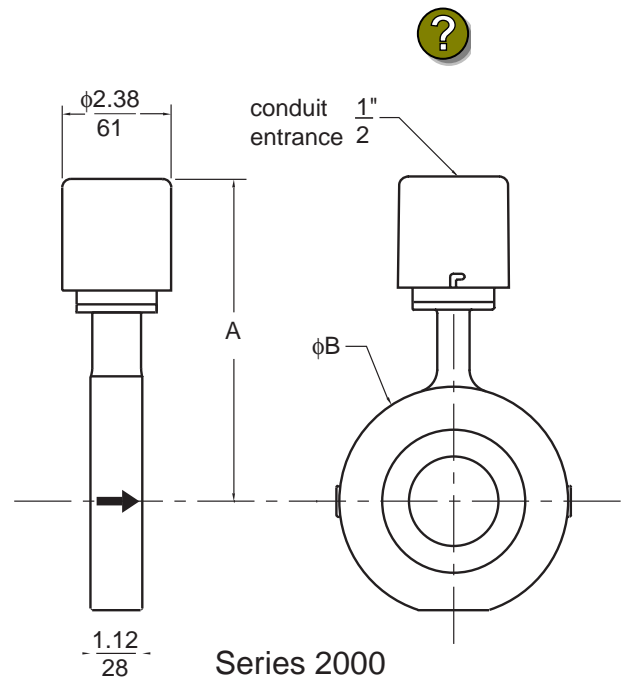
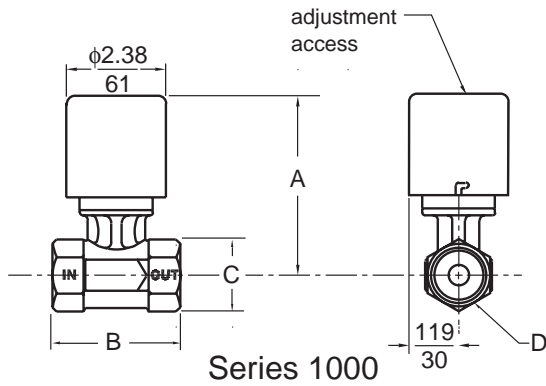

Pipe Size		Dimension								
		A		B		C		D		
in	mm	in	mm	in	mm	in	mm	in	mm	
0.25	08	3.46	88	3.06	78	1.06	27	1.06	27	sq
0.5	15	3.46	88	3.06	78	1.06	27	1.06	27	sq
0.75	20	4.18	106	3.06	78	1.50	38	1.25	32	hex
1.0	25	4.30	109	3.06	78	1.75	44	1.50	38	hex
1.5	40	4.68	119	3.06	78	2.50	64	2.12	54	hex
2.0	50	5.05	128	3.19	81	3.19	81	2.75	70	hex
3.0	80	5.74	146	4.19	106	4.62	117	4.00	102	hex

Pipe Size		Dimension			
		A		B	
in	mm	in	mm	in	mm
0.5	15	4.85	123	1.69	43
0.75	20	5.29	134	2.00	51
1.0	25	5.48	139	2.38	60
1.5	40	6.04	153	3.12	79
2.0	50	6.23	158	3.75	95
2.5	65	6.73	171	4.25	108
3.0	80	7.10	180	5.00	127
4.0	100	8.17	207	6.13	156
5.0	125	8.57	217	7.38	187
6.0	150	9.29	235	8.38	213
8.0	200	10.54	267	10.38	264

ORDERING

E **B S**

Size: 2 Inches

Series: 1 000 Threaded
2 000 Flanged

Material: 1 Bronze
3 316 Stainless Steel

Maximum Flow Range: 20 GPM
(select from table of flow ranges and sizes; prefix with "M" for metric units; specify units if necessary)

Options: A - Viton seals
B - EPR seals
B2 - TFE seals
ES - low flow rate
I - compressed gas service
K - steam service
T - expanded temperature range

Switch quantity and type:
1S2 - one SPDT switch
2S2 - two SPDT switches

RCM Industries, Inc.

Northeast Controls Incorporated
P.O. Box 275 - 123 Pleasant Avenue
Upper Saddle River, New Jersey 07458 USA
Tel: 201-327-7660 | Fax: 201-327-3242
email: sales@northeastcontrolsinc.com
www.northeastcontrolsinc.com